

Toward a Dynamic, Context-Sensitive Research Network Information System Specification Method¹

Aldo de Moor²
Tilburg University

Nardo B.J. van der Rijst
Delft University of Technology

Abstract

In this paper we propose a dynamic and context-sensitive specification approach aimed at the development of research network supporting information systems. We do this by combining the research network reference framework RENISYS with the dynamic information system development method DEMO. By offering research networks more advanced ways of structuring the modeling of their collaboration processes and the resulting information systems, we may expect a significant increase in long-term results.

Introduction

Research networks are professional human networks that focus on facilitating certain stages of the research process by supporting their members in accomplishing shared and individual professional goals (de Moor, 1995). Parts of the research process that can be supported are the planning and conduct of research and the dissemination and implementation of the results (de Moor, 1994). As such, research networks act as interfaces between researchers and the persons influencing and depending on their work, provided that the networks and the supporting information systems are well-designed.

A research network can be viewed as a kind of complex organization. It is essential that flexible information system development methods can identify required changes in activities in line with the desired objectives of the organization (Galliers, 1993). We propose that in order for systematic change identification to be feasible, such a method must be both dynamic and context-sensitive.

One defining characteristic of research networks is their dynamism: they are always in flux. This changeability not only affects the members of the network but also results in continuously changing, hard to define information systems. To address this problem, the specification method must be dynamic: it must allow for the easy evolution of system specifications.

Having a dynamic method is not sufficient. System developers who use it must also know what topics to focus their attention on and which questions to ask. The method therefore needs to be context-sensitive as well: it must take into account the characteristics of the context in which the information system is situated, so that the likely determinants of change can easily be discovered. We distinguish three main categories of information system determinants: the network problem domain, the human network (organization), and the enabling information technologies. In this paper, we abstract from these technologies as they are not really essential to a better understanding of the modus operandi of the network.

The information system dynamics and context-dependence result in considerable specification problems as most of the current network information system development is a one-time event and technology-driven only, instead of being a continuous, context-driven process. This means that the resulting information systems often consist of functionally unsatisfactory, rapidly outdated sets of information tools with ill-defined sets of data. In order to develop more flexible, maintainable, and extensible research network information systems, a dynamic information

¹ Published in the Proceedings of the 13th International Association of Management Conference, Vancouver, August 2-5, 1995, pp. 108-117.

² Aldo de Moor, Infolab, Tilburg University, The Netherlands, E-mail: ademoor@kub.nl; Nardo van der Rijst, Department of Information Systems, Delft University of Technology, The Netherlands, E-mail: vdrijst@is.twi.tudelft.nl. Correspondence concerning this article should be addressed to Aldo de Moor, Infolab, Tilburg university, P.O. Box 90153, 5000 LE Tilburg, The Netherlands, Tel: +3113663020, Fax: +3113663069.

analysis approach is needed which allows specified concepts to be reused and evolve and takes into account context-knowledge during the development process.

In this paper, we ask ourselves the question how we can create such an 'enriched' dynamic information system specification method for research networks. We attempt to sketch its contours by combining one context reference framework currently being designed for the specification of research network information systems with a generic dynamic information system development method. The reference framework used here is that which will form the basis of the Research Network Information System Specification method (RENISYS) of which the basic ideas are described in (de Moor, 1995). The information system development method is the Dynamic Essential Modeling of Organizations approach (DEMO) as described in (Dietz, 1994a).

Although there are already many research networks using information technologies, especially Internet-based ones, the level of systematic information system development support is currently rather low. As a consequence, the effectiveness of these networks is seriously hampered. By offering research networks more advanced ways of structuring their collaboration and information system modeling processes (which are not imposed, but defined by the group itself as an ongoing process), we may expect a significant increase in long-term network results. In this way, not only the quality of science itself can be improved, but also the way in which the scientific results are disseminated in society. Secondly, the specification method may also be useful in modeling other areas of professional cooperation such as taking place in business networks (Jarvenpaa & Ives, 1994), (Kambil & Short, 1994).

We first briefly introduce RENISYS and DEMO. After that, we will use the concepts of DEMO to fill in the RENISYS framework. We will do this by studying a case drawn from an existing research network. We will then discuss the issues raised by using this approach and conclude with some recommendations on how to proceed from here.

The RENISYS Method

The RENISYS framework consists of three levels: the problem domain, the human network, and the information system. In the problem domain, the network goals are described and the activities that the network participants need to carry out in order to achieve these goals.

In the human network the organizational structure is defined in which the activities are performed. The human network consists of four sub-levels: the individual, the group, the network and environment level. Each activity from the problem domain is represented at the human network level as a combination of human information and communication processes (I/C processes), such as decision making, negotiation, co-authoring and so on.

Finally, the information system level describes the high level specifications of the actual network information system. Each human information and communication process from the human network level is translated into a number of human-machine and machine-machine information and communication processes, such as retrieving and filtering of information. Figure 1 shows the relationships between the three levels. In this paper we will refrain from describing the information technologies implementing the information system level. Examples are Intermedia (Yankelovich, Haan, Meyrowitz & Duckers, 1988) and WWW/Mosaic (Andreessen, 1995).

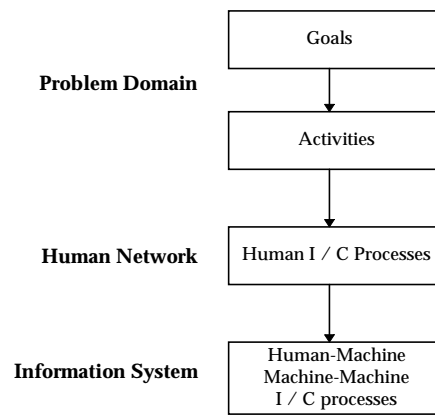

Figure 1: The RENISYS Framework

The DEMO Method

DEMO is an acronym for Dynamic Essential Modeling of Organizations. It is the name of a cross-disciplinary theory about the dynamics of organizations, as well as an analysis method. The disciplines on which it draws are the philosophical branches of semantics and scientific ontology (Bunge, 1979), and the social theory grounded in language philosophy (Searle, 1969), (Habermas, 1981). Next to these it incorporates the discrete dynamic system theory as described in (Dietz, 1990). Other related modeling approaches are SAMPO (Auramäki, Lehtinen & Lyytinen, 1988) and BDL (Medina-Mora, Winograd, Flores & Flores, 1992).

In DEMO three levels of abstraction are identified (Dietz, 1994a; Dietz, 1994b). At the lowest level, called the documental level, an organization is viewed as a system of actors that produce, store, transport, and destroy documents. At the informational level, one abstracts from the substance in order to focus on the semantic aspect of information. At the highest level of abstraction, the essential level, the essence of the organization is captured by viewing actors carrying on performative conversations resulting in original new things. These conversations represent the essence of an organization.

The core modeling concept of DEMO is the concept of the (essential) transaction. A transaction is considered to be the basic pattern of organizational behavior. It evolves in three phases: actagenic, action and factagenic. During the actagenic phase agreement is reached between actor A and actor B about the future execution of an action by actor B. This phase consists of an actagenic conversation, initiated by actor A. The result is an agendum (singular of agenda) for the execution of an essential action by actor B. During the action phase this essential action is executed by actor B. During the last phase actor A and actor B reach agreement about the facts that have been accomplished as a result of the execution by actor B. It consists of a factagenic conversation. Actor A is called the initiator of the transaction and actor B the executor. The behavior of a business (or any organization) thus is conceived as consisting of carrying through transactions. Every (essential) action is embedded in a transaction and every established fact is the result of the successful carrying through of a transaction.

The essential model of an organization is an integrated whole of several partial models. The communication model (CM) of an organization is the specification of the interaction structure and the interstriction structure between actors. By interaction structure is understood the mutual influencing through being initiator or executor of transactions. By interstriction structure is understood the mutual influencing by means of created facts that play a role in the condition part of the behavioral rules that are executed in carrying through transactions. A CM is graphically represented by means of a communication diagram. The object world (or things actors communicate about) is defined in the facts model (FM), while the behavior of the actors is specified in the action model (AM) by means of a procedural language. Furthermore, low level transaction process models (TPM) describe individual steps in individual transactions and high level transaction process models describe the relation between the different transactions in time.

The DEMO approach has been used for the analysis of communication and information structures in very diverse types of organizations. In Dietz (1994b) the method is also proposed as a business (re)design method. Especially this last feature is used in this research project as it is the sensitivity to changes occurring in the subject and object system of the research network that is so important in modeling methods of dynamic systems.

In this paper, we only focus on defining the essential communication models as they form the core of any DEMO analysis. In future work we will extend our analysis to the other possible models as well. An example of a complete specification can be found in (van der Rijst & van Reijswoud, 1995).

Integrating RENISYS and DEMO

From this short introduction into the basic concepts constituted by RENISYS and DEMO, we can conclude that the following starting points are important for developing a method that models human research networks and their supporting information systems:

1. Participants in the research network are viewed as responsible subjects performing tasks in the network. Tasks in the research network are called actors. Conducting tasks is performed in the role of executor or initiator of the tasks at hand (e.g., a customer is the initiator of the process of the delivery of certain items. The executor is the supplier of the goods. In our example case study we can think of a moderator of a mailing list, a contributor etc.).

2. Each activity and I/C process can consist of sequences of, sometimes conditional or repeated, subprocesses. Every subprocess is modeled by defining a number of interlinked transactions, each of which is determined by (A) a set of actors responsible for carrying out individual actions and (B) the communicative actions taking place between actors. The aim of the transactions is to coordinate the individual actions carried out by actors in the real world. The sequence of these transactions in time is represented in a high level transaction process model.
3. Every transaction is modeled as a combination of speech acts in a low level transaction process model.
4. Next to the definition of the interaction structure between actors, constituting of the transactions, we also represent the interstriction structure by means of the results of informative conversations (e.g. obtained by consulting a database).

Before we can illustrate the potential of the method by modeling part of a case, we first need to explain more about the structure of the method. We distinguish between the network information system development- and operational level. At the operational level, the network structures and procedures are considered fixed, only their instantiations can change. At the development level, these network concepts can be changed if necessary. In other words, the operational level concerns the modus operandi of the network, the development level is the meta-level at which the operational level is shaped. This means that for example when system developers and their tasks are modeled, the development process itself can be much better formalized.

Because the method allows the information system to evolve rapidly, we must tightly integrate the specification of the system development processes with the processes occurring during the actual system use. In other words, if the information system specification method is to be really useful, we cannot limit ourselves to just modeling the problem domain, human network and information system; we must also model the processes taking place at the meta-level and especially the links that they have with components from the operational level. Once these links between the development and the operational level have been well-defined, it becomes much easier to represent such constraints as who has the authority to make changes and in what way decisions are being made on the network infrastructure. For example, the method being user-driven means that certain participants specified in the human network can have the privilege to change the descriptions of the network goals. Due to the formalization of the development level processes this can be relatively easily specified.

The Case: Group Report Writing in a Research Network

By means of a case we want to show the ease with which specifications can be modified with the RENISYS-DEMO combination. To do so, we will show how participants in a research network can model in an evolutionary way a specific network activity, and of course the resulting changes in the information system. The selected activity is that of writing a group report. Group reports are important end products of scientific research networks, but their production is as of yet still little supported by existing network information systems. The exact procedures to be followed in writing them are difficult to determine and highly dependent on the peculiarities of the specific research network. Thus, only after a lot of experimentation will the group participants be able to determine an acceptable information system. In order to be able to quickly specify and implement the many needed intermediate information systems, RENISYS-DEMO can prove to be useful.

We will start by modeling a simple research network problem domain, human network and information system module at $t=0$. At this stage in the network development, there is only a simple mailing list available on which network participants can freely discuss any topic they deem relevant. Not much group-goal oriented discussion takes place, so group report writing is virtually non-existent.

At $t=1$ the group, unsatisfied with the current unfocused interaction, decides to work out a group report writing activity (how exactly this is decided is something to be defined at the development level, which is not further explained in this paper). We will show here a simplified version of the report writing process currently being discussed in the Global Research Network on Sustainable Development (GRNSD). This is an independent network that studies the sustainable development research process and aims to find ways to increase its effectiveness and efficiency³ (de Moor, 1994).

³ More information is available on the GRNSD WWW server at URL <http://infolabwww.kub.nl:2080/grnsd>

We first give some example informal specifications as they can be defined at the various RENISYS levels. In between these levels we show some example mapping constraints. After that we will show for each case the DEMO representation.

Regular Group Discussion

Most research networks that are supported by an information system do not specifically support the group report writing process. In general, they have a mailing list available, via which everybody having an idea about what to include in the report or list can send messages to all other group members. The entities distinguished are author, mail, and mailing list. Needless to say that this is a very primitive and ineffective way of co-authoring. For example, no specific procedures have been defined that are able to deal with conflicting opinions.

For both examples the following two assumptions hold:

- Each element from the Problem Domain is part of the Human Network and Information System
- Each element from the Human Network is part of the Information System

Informal specification

Problem Domain (PD)

- Author1 sends document1 to audience
- Author2 (member of audience) replies to document1 with document2
[Repeat]

Mapping Constraints:

- { Author1, Author2 } = group member
- audience = group

Human Network (HN)

- Group_member1 sends document1 to group
- Group_member2 replies to document1 with document2
[Repeat]

Mapping Constraints:

- All group members have an account and are users
- Document = text_file

Information System (IS)

- User1 mails text_file1 to group mailing list
- User2 edits text_file2 in reply to text_file1 and mails to group mailing list

This stage is further specified with the DEMO approach. For this first case a rather arbitrary type of actors is defined. Because of the lack of commitments between the participants in a mailing list actually no direct interstriction structure exists. A direct influence is represented in the interaction structure between actors in their role of initiator or executor in a transaction (see paragraph discussing the DEMO approach).

Table 1: Transaction table of regular group discussion

Transaction	Initiator	Executor
T1 Send_Doc	A1 Author1	A1 Author1
T2 Reply_Doc	A2 Author2	A2 Author2

Only two transactions are identified: sending a document (T1) and replying to this document (T2). Both transactions are considered to be self-activating. The participants in the communication structure use informative links see (van der Rijst & van Reijswoud, 1995) to read and inform themselves about the newly created facts (i.e. documents). There is no direct regulated communication between the participants. When this process is translated to a Transaction Process Model (van Reijswoud & van der Rijst, 1995), describing the relationships between the transactions in time, the process looks like a repetitive chain of the two defined transactions. The actual mailing list will show a monotonous growing process.

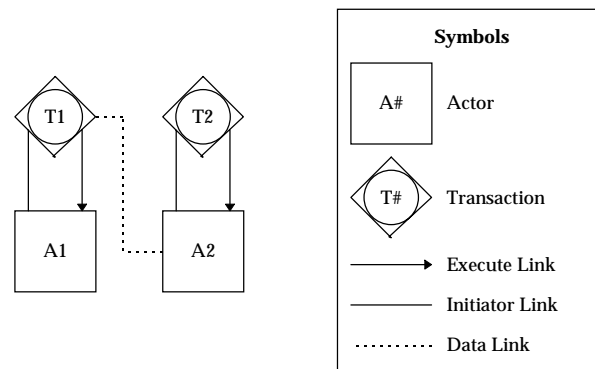

Figure 2: Communication Diagram of the regular group discussion

The GRNSD Group Report Writing Process

In the GRNSD Group Report Writing Protocol⁴ some guidelines are given concerning the way in which reports need to be constructed.

However, these guidelines are still rather vague and need to be worked out in much greater detail. One of the GRNSD groups is now doing just that. However, for now we will just use our own simplified version based on the following section of the current protocol. Due to limited space available, we only define the steps involved for the problem domain (PD).

'- GRNSD reports must ... be 'multiple consensus' based. This means that the group that prepares a report first lists the issues on which it agrees. Then, it formulates different alternatives for the elements on which members cannot reach agreement. Every member has the right to define an alternative.'

Informal specification

- Topic creator sends topic to audience
- Audience approves of topic
- Contributor sends topic_contribution to audience
- Attacker sends modification of topic_contribution to audience
- Defender sends approval of topic_contribution to audience
- Editor creates final report

In this typical example the assumption is that the topic remains constant, but in a different case the process described for the contributions could also be used for the topic definition/modification process.

For the object world facts the following has been defined:

1. The final report consists of topic, consensus part and dissensus part,
2. The consensus part consists of topic_contributions where_not exist modifications of topic_contributions,
3. The dissensus part consists of topic_contributions where exist modifications of topic_contributions.

⁴ URL <http://infolabwww.kub.nl:2080/grnsd/reports.html>

In this advanced case the commitments are more complex. Some commitments are explicit while others are implicit (e.g., a non-response is considered an approval). DEMO allows for the clear representation of these complex interactions and interstrictions.

Table 2: Transaction table of advanced process

Transaction	Initiator	Executor
T1 Create Report	A1 Network-Group	A2 Editor
T2 Set Topic	A1 Network-Group	A3 Topic-Creator
T3 Send_Submission	A1 Network-Group	A4 Contributor
T4 Attack_Section	A5 Attacker	A5 Attacker
T5 Approve_Section	A6 Defender	A6 Defender

The communication diagram of the group report writing case can be explained as follows. After an initial period of free exchange of opinions, a discussion on the topic will start. The whole process of writing a group report starts with the initiation of the transaction T1 by the Network Group (A1). This transaction will end when the report has been compiled by the Editor (A2). Established topics are used as a guideline by the contributors (A4) to restrict what they can submit as their contributions. This restriction is represented by the informative link between the actor A4 and the transaction T2. Approvals and disapprovals of the contribution are sent in by the defenders (A6) and attackers (A5), respectively. Both actors use informative links with transaction T3 to collect information about the submissions. Finally, the group appointed Editor (A2) compiles the actual group report.

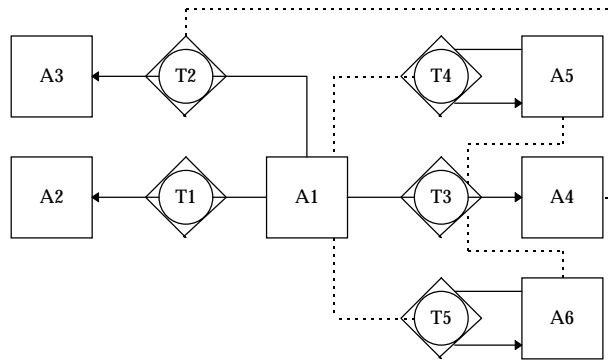

Figure 3: Communication Diagram of the group report writing example

Discussion

The DEMO model of the regular group discussion problem domain clearly shows that group goals are lacking: there is an endless loop of contributions of authors exchanging messages, without committing themselves in any way to other authors. Contrary to this, the DEMO specification of the advanced group report writing process makes clear that participants commit themselves to carry out individual actions that are dependent on those of other participants in different roles. The specifications could be the basis for corrective actions such as specifying sanctions if participants who committed themselves do not deliver.

Crucial to the RENISYS approach are mapping processes, which are defined at the development level. Mappings can be classified along two dimensions: the temporal dimension and the complexity dimension. Each of these dimensions results in two types of mappings.

Mappings in the temporal dimension are either instantaneous mappings or sequential mappings. Instantaneous mappings are the mappings that determine relationships between concepts from different subsystems at a certain point in time. For example, an author in the problem domain can be represented as a group member in the human network. On the other hand, the sequential mapping takes a concept from a specific domain and determines how it and its relationships with other concepts change over time. For example, a 'send file' process in the information system can be redefined from simply sending a file to sending a file and logging it in a sent-file database as well.

Mappings that can be distinguished according to the complexity dimension are simple mappings or complex mappings. A simple mapping involves a mapping of one or a cluster of concepts to exactly one other (cluster of) concept(s). Sending a document in the human network is translated into mailing a text_file in the information system. In complex mappings, however, a concept in one domain is translated in more than one concept in the other domain, a 1:n transformation. Here, one could think of an author in the problem domain consisting of various interacting network groups at the human network level.

It is important that the method enforces procedures related to certain types of mappings, so that for example with sequential mappings no ambiguities can be created during network specification transition, because old, superfluous concepts have not been redefined in terms of the new ones.

One of the main advantages of using DEMO in this specification framework is its high level but still formal representation of communication problems. Although we have given only a small example of how to create network information system specifications, the general mapping mechanisms already defined show the ease with which roles of the participants in one subsystem can be mapped to other subsystem roles as well as maintained in time. Another advantage is the natural way of representing commitments between participants. This feature is especially important in the maturation of research networks and their IS, where complex tasks with often far reaching implications need to be divided among participants.

The synthesis of RENISYS with DEMO helps to model problem domain, human network and information system constraints in a much more formal way, as they and their mappings can now be defined in primitive terms of transaction components and their constituent speech acts, which themselves have a good formal basis. At least two categories of constraints need to be distinguished: (1) operational constraints that limit the possible configurations and combinations of actors, processes, objects, etc. within a subsystem and (2) mapping constraints that limit the possible translations that can be made between elements from different subsystems. An example of the second type of constraint could be that all concepts from the problem domain have at least one counterpart in the human network. The exact way in which these constraints should be modeled and grouped has not been investigated yet, this should be the object of future research.

Related Research

Research networks as a focus of information system support have not received much attention yet. Kraut, Galegher & Egido (1987) describe different stages of scientific cooperation and how coordination can be achieved. Rechenman (1993) proposes a distributed knowledge base architecture by means of which researchers can share knowledge at different consensus levels. This architecture is a formal equivalent of the reviewing process rather than the report writing process we described in this paper. In Wan & Johnson (1994) a system called CLARE has been developed that aims at collaborative learning through collaborative knowledge construction. So, although the emphasis is on learning, the process is very similar. A major difference is that our ultimate goal is the development of a framework by means of which the members of the network can choose and adapt different ways of working, whereas the above systems typically support one way. For that reason, we have started with a general communication modeling method DEMO.

The same point also applies when we compare our approach with related research not aimed at research networks such as negotiation protocol described in Chang & Carson (1994). This protocol is based on speech acts. Negotiation by means of speech acts is also part of the Transaction Process Model in DEMO. However, DEMO highlights the commitments of the participants resulting from successful transactions.

Conclusions and Future Research

The development of a comprehensive specification method for research networks information systems has been given an initial impetus in this paper. Conventional methods are hardly capable of tracking down and modeling the dynamism and context of research network information systems. In order to deal with these problems we chose to combine the research network information system context framework RENISYS with the DEMO analysis approach. The ideas presented here are only the first steps on the long way to a mature method. Activity and information and communication process models still need to be developed. Concept and constraint types, mapping processes and other development procedures need to be worked out in much more detail before a working method can be realized. Reference models need to be created that capture context knowledge present in the problem domain, human network and information system and thus help guide the development process. The development of these reference models will to a large extent be based on the results of several case studies.

Acknowledgment

We would like to express our gratitude to Hans Weigand for proof reading earlier versions of this paper.

References

- Andreessen, M., (1995) NCSA Mosaic technical summary. Available via anonymous ftp from "ftp.ncsa.uiuc.edu:/Web/mosaic-papers"
- Auramäki, E., Lehtinen E., Lyytinen K., (1988) A Speech Act Based Office Modeling Approach, *ACM Transactions on Office Information Systems*, Vol. 6, No. 2, 126-152.
- Bunge M.A., (1979) *Treatise on Basic Philosophy*. Vol. 1, Vol. 2, Vol. 3 and Vol. 4, D. Reidel Publishing Company, Dordrecht.
- Chang, M.K., Carson, C.W., (1994) A Speech-Act based Negotiation based Protocol: design, implementation and test use, *ACM Transactions on Information Systems*, Vol. 12, No. 4, 360-382.
- Dietz J.L.G., (1990) A Communication Oriented Approach to Conceptual Systems Modelling. *Proceedings of the 1990 Working Conference on Dynamic Modelling of Information Systems*, Noordwijkerhout, 37-60.
- Dietz J.L.G., (1994a) Business Modelling for Business Redesign. *Proceedings of the 27th Hawaii International Conference on System Sciences*, IEEE Computer Society Press, Los Alamitos, CA, 723-732.
- Dietz J.L.G., (1994b) Modelling Business Processes for the Purpose of Redesign. *Proceedings IFIP TC8 Open Conference on Business Process Redesign*, Australia, North-Holland, 249-258.
- de Moor, A., (1994) The Global Research Network on Sustainable Development: Working Together on Our Common Future, *Research Report Tilburg University*.
- de Moor, A., (1995) Toward a More Structured Use of Information Technology in the Research Community, Submitted for publication.
- Galliers, R.D., (1993) Towards a Flexible Information Architecture: integrating business strategies, information system strategies and business process redesign, *Journal of Information Systems*, Vol.3, 199-213
- Habermas J., (1981) *Theorie des kommunikativen Handelns*. Erster Band, Suhrkamp Verlag, Frankfurt am Main.
- Jarvenpaa, S.L., Ives, B., (1994) The Global Network Organization of the Future: Information Management Opportunities and Challenges, *Journal of Management Information Systems*, Spring, Vol.10, No.4, 25-57
- Kambil, A., Short, J.E., (1994) Electronic Integration and Business Network Redesign: A Roles-Linkage Perspective, *Journal of Management Information Systems*, Spring, vol. 10, No. 4, 59-83.
- Kraut, R., Galegher, J., Egido, C., (1987) Relationships and tasks in scientific research collaboration, *Human-Computer Interaction*, 3 (1), 31-58.
- Medina-Mora, R, Winograd T., Flores R., Flores F., (1992) The Action Workflow Approach to Workflow Management Technology, *Proceedings of the Conference on Computer Supported Cooperative Work*, ACM, 281-288.
- Rechenmann, F., (1993) Building and sharing large knowledge bases in molecular genetics, *Proceedings KB&KS workshop*, Tokyo, 291-301.
- Searle J.R., (1969) *Speech Acts: An Essay in the Philosophy of Language*. Cambridge University Press, Cambridge.

- van der Rijst N.B.J., van Reijswoud V.E., (1995) Comparing speech act based modeling approaches for the purpose of IS development, *Proceedings of the 3rd European Conference on Information Systems*, Athens, 353-365.
- van Reijswoud V.E., van der Rijst N.B.J., (1995) Modelling Business Communication as a Foundation for Business Process Redesign: A Case of Production Logistics. *Proceedings of the 28th Hawaii International Conference on System Sciences*, IEEE Computer Society Press, Los Alamitos, CA, 841-850.
- Wan, D., Johnson, P., (1994) Computer Supported Collaborative Learning Using CLARE: the approach and experimental findings, *Proceedings of the Conference on Computer Supported Cooperative Work*, ACM, pp. 187-198.
- Yankelovich, N., Haan, B.J., Meyrowitz, N.K.Y., and Duckers, S.M., (1988) Intermedia: The concept and the construction of a seamless information environment, *Computer*, January.